



The Crystal Well

The story

The three characters seated around the table all had a problem to solve, but they all came together in a single, shared problem, the construction of a full size crystal well.

Giampiero Muzzi, the photographer, wanted to see his idea made tangible, Duccio Santini, the architect, wanted to offer his design response to the idea and Vasco Conti, the owner of the Duccio di Segna crystal-works, wanted to offer a demonstration of his company's skills and potential. Three challenges in one! Things progressed amidst endless discussions, constructive reorganizations, tests and alterations. Then the final choices gave their fruits. The various components of the well became reality.

Vasco had built a special room dedicated to the crystal well, which was immediately named the drawing room. Duccio drew the shapes which were gradually refined and defined, directly on the wall, and these were then transformed into surprising realities thanks to the craftsmanship of Vasco. The well grew almost day by day and Giampiero bore witness to the event, immortalising the changes with his camera, inventing angles and skilful lighting effects. Now this wonderful adventure is over, the three characters have achieved their aims and are no longer seated around a table, preferring to spend time looking with satisfaction at the magnificent well which has now become an artistic installation which cannot be described but only admired.

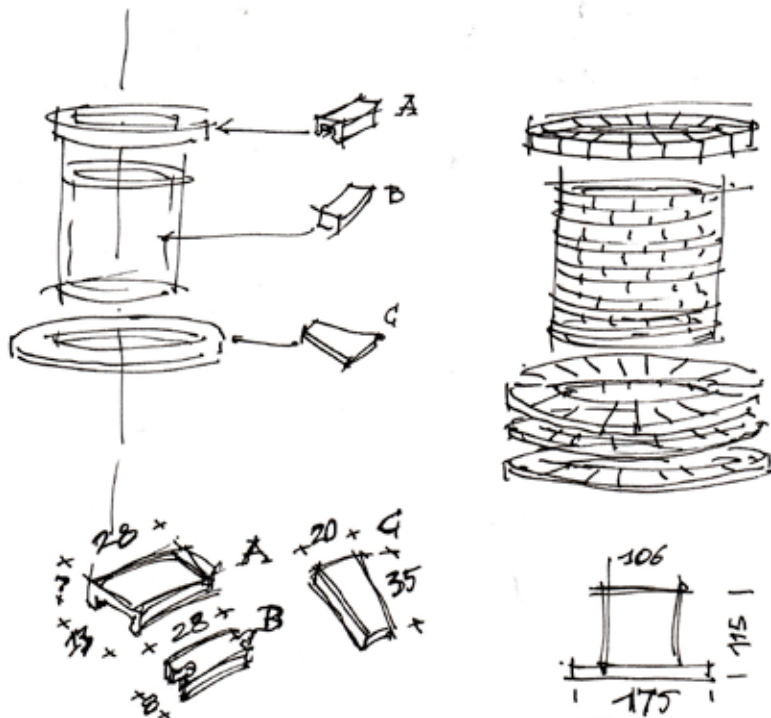

The fourth character will be the person who is able to fully appreciate and understand the emotional and artistic value of this work and who can offer it a space in which to enjoy its secret charm.



Duccio Santini architect

Duccio Santini is an eclectic artist and he divides his creative commitment among architecture, design, illustration and installations made of crystal.

He considers every artistic discipline as complementary to the others, in the belief that there is no net boundary between them, other than the boundary he traces as and when he sees fit, pursuing his fantasies and his dreams.



Vasco Conti - businessman

The Duccio di Segna crystal-works has been making the finest objects in 24% lead crystal since 1984, spanning from design to art.

Vasco Conti, owner of this important production activity, boasts years of experience in this sector and his entrepreneurial skills make it possible for him to undertake adventures of this kind.

Today the pride and joy of Duccio di Segna is the production of unique items, real works of art.

*...Andrea raccoglieva violette
ai bordi del pozzo,
Andrea gettava riccioli neri
nel cerchio del pozzo.
Il secchio gli disse - Signore
il pozzo é profondo
più fondo del fondo
degli occhi della notte del pianto...*

These are the beautiful,
mysterious words of a song
by Fabrizio De André.

Bending over a well and looking into it is
a bit like heading into the unknown.
Saying a name, in a low voice, with your
head leaning into the void will certainly
create an echo which will come back at
you from the bottom, maybe thudding,
threatening, but perhaps also inviting,
sensual. And if you want to give a face to
that name, that will look back at you from
the surface of the water and the darkness
of that place, you will have to be very
careful, because you cannot be sure that
you won't be filled with an immediate
desire to join it, given that the attraction
of a meeting in that place would be very
strong and the meeting as eternal, pure
and sparkling as crystal.



Giampiero Muzzi - photographer

Giampiero Muzzi works mainly in the
furnishing sector, while embracing
every aspect of photography.
He is a director of artistic videos and
promotional commercials.
The fact that he was born in Colle di Val
d'Elsa, where over ninety percent of Italy's
crystal tableware is made, has encouraged
a relationship with this material which,
besides being professional, is also
“creative” with regard to photography and
filming.
In recent years he has developed some of
his intuitions and ideas (like “il pozzo” –
the well) which have subsequently been
transformed into sculptures.



The burning furnace with the state-
of-the-art equipment and skill of
the craftsmen employed by Duccio
di Segna generate works of art that
comply perfectly with ancient Tuscan
traditions.



a square
a cloister
a farmhouse
a well
the centrality
the fulcrum
a well creates a place
a well is life
it is architecture
bending over a well
looking inside at reflected images
fantastic reflections
fantasies
the moon in the well
the wishing well
imagination
imagine a crystal well
sparkling
ethereal
married to light
lightness
a real well of wonders
a wonder in itself
a dream machine
crystal blocks embracing one another
climb concentrically to create
a cylindrical wall
the imagination runs to see
the crystal well
that creates fantastic spaces
around itself
conversing
with wonderful places

Duccio Santini



480 pieces of handmade solid crystal weighing 2400 kg with a height of over 2 metres



Duccio di Segna
Cristalleria

Duccio di Segna srl
Colle di Val d'Elsa (SI) Loc. Pian dell'Olmino, 42
Tel. +39 0577 929656 Fax +39 0577 929522
info@ducciodisegna.com
www.ducciodisegna.com